

mitsubishi

Industrial Sewing Machine

TECHNICAL INFORMATION

Automatic Undertrimmer, Needle Feed, Single-Needle Lookstitch

Model LS2-2210

ET-036

CONTENTS

| | |
|---|------|
| 1. CONSTRUCTION | 2 |
| 1.1 Needle Feed Mechanism..... | 2 |
| 2. SPECIFICATIONS | 3 |
| 3. THREAD TRIMMER SYSTEM | 4~6 |
| 3.1 Electric Section..... | 4 |
| 3.2 Machine Head Section (1)..... | 5 |
| Machine Head Section (2)..... | 6 |
| 4. PREPARATIONS BEFORE OPERATION | 7~8 |
| 4.1 Installation of Sewing Machine and Motor..... | 7 |
| 4.2 Adjustment of Machine Stop Position..... | 8 |
| 4.2.1 Adjust of "UP" position | 8 |
| 4.2.2 Adjust of "DOWN" position | 8 |
| 4.2.3 Comfirm the stop operation then the plug (12pins) coming from the machine head into the receptacle | 8 |
| 5. ADJUSTMENTS | 8~18 |
| 5.1 How to Adjust the Timing between Needle and Hook..... | 8 |
| 5.2 Thread Trimmer Mechanism | 9 |
| 5.2.1 Construction | 9 |
| 5.2.2 Cautions on adjustment..... | 9 |
| 5.2.3 Installation of knife base and fixed blade bracket unit..... | 9 |
| 5.2.4 Connection of knife base and knife driving crank..... | 10 |
| 5.2.5 Knife driving shaft and related parts..... | 10 |
| 5.2.6 Installation of thread trimmer solenoid unit..... | 11 |
| 5.2.7 Installation of thread trimmer cam..... | 11 |
| 5.2.8 Adjustment of knife engagement..... | 12 |
| 5.2.9 Adjustment of needle thread tension releasing amount..... | 13 |
| 5.3 Adjustment of Needle Thread Remaining Length..... | 13 |
| 5.4 Cautions on Installation of Touch-Back Solenoid | 13 |
| 5.5 Touch-Back Pushbutton | 13 |
| 5.6 Wiper..... | 14 |
| 5.6.1 Height of wiper | 14 |
| 5.6.2 Wiper operation position | 14 |
| 5.7 Adjustment of Forward and Reverse Stitch Lengths..... | 14 |
| 5.8 Adjustment of Feed Dog Inclination | 14 |
| 5.9 Timing of Feed..... | 15 |
| 5.10 Relation between Needle and Feed Dog..... | 16 |
| 5.11 Adjustment of Needle Feeding Amount..... | 17 |
| 5.12 Hook, Bobbin Case, and Bobbin | 18 |
| 6. TROUBLESHOOTING | 19 |

1. CONSTRUCTION

1.1 Needle Feed Mechanism

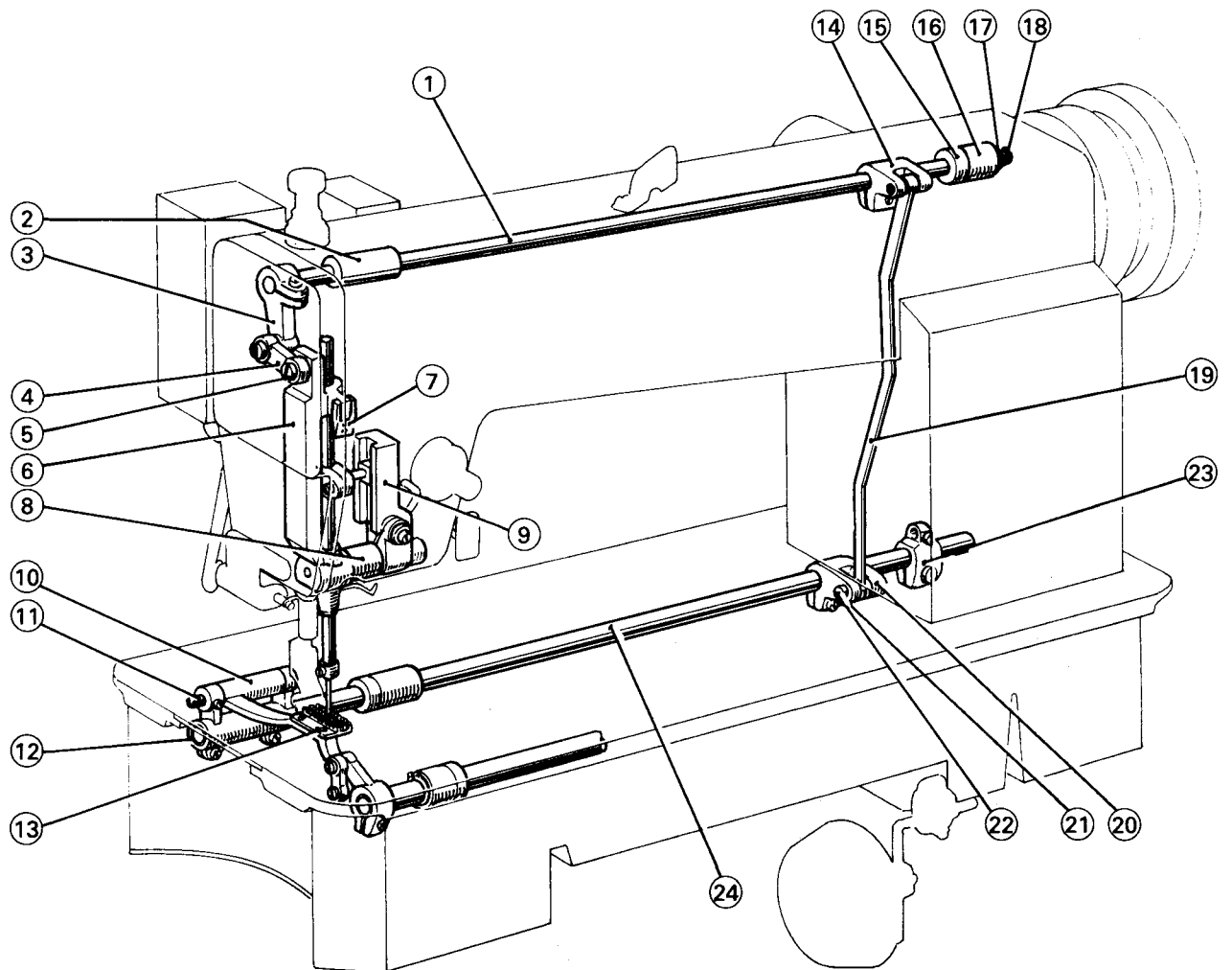

Part Names

- | | | |
|-----------------------------------|-------------------------------------|--------------------------------|
| ① Needle feed shaft | ② Needle feed shaft metal (left) | ③ Needle feed rod crank (left) |
| ④ Link | ⑤ Set pin | ⑥ Needle bar supporter |
| ⑦ Needle bar supporter guide | ⑧ Needle bar supporting shaft metal | ⑨ Needle bar guide crank |
| ⑩ Feed bar | ⑪ Eccentric shaft | ⑫ Feed rock shaft crank (left) |
| ⑬ Feed dog | ⑭ Needle feed rock crank (right) | ⑮ Collar |
| ⑯ Needle feed shaft metal (right) | ⑰ Washer | ⑱ Retaining ring |
| ⑲ Needle feed Rod | ⑳ Needle feed driving crank | ㉑ Set screw |
| ㉒ Eccentric Set pin | ㉓ Feed rock crank (right) | ㉔ Feed rock shaft |

2. SPECIFICATIONS

| Item | Model | LS2-2210-MIT | LS2-2210-MITW |
|--|-------|---|---------------|
| Material weight | | Light to medium | |
| Max. sewing speed, spm | | 5,000 | |
| Stitch length, mm | | 0 to 4 | |
| Needle bar stroke, mm | | 31.8 | |
| Presser foot stroke, mm (Knee lifter/Manual) | | 11/5 | |
| Needle | | DBX1-2 #14 | |
| Hook | | Fully-rotating automatic lubrication (for thread trimmer) | |
| Bobbin case | | With idle running prevention spring | |
| Bobbin | | Made of steel, for thread trimmer | |
| Thread trimmer | | Rotary scissoring by left movable knife and right fixed blade | |
| Thread trimmer starting | | Solenoid actuation | |
| Knife drive | | Cam drive | |
| Touch-back | | ○ | |
| Wiper | | - | ○ |
| Oil | | MC70M | |

3. THREAD TRIMMER SYSTEM

3.1 Electric Section

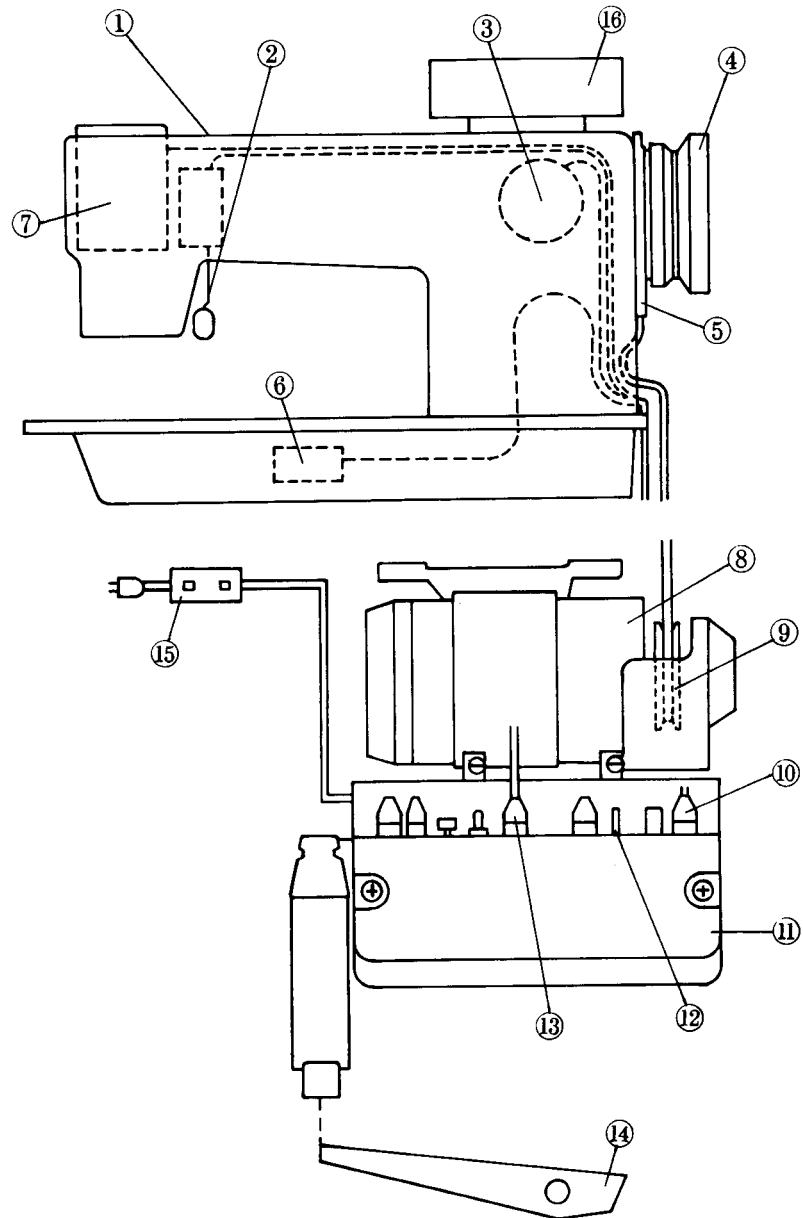

Part Names

- | | | |
|----------------------|----------------|---------------------------|
| ① Sewing machine | ② Touch switch | ③ Back solenoid |
| ④ Balance wheel | ⑤ Synchronizer | ⑥ Thread trimmer solenoid |
| ⑦ Wiper solenoid | ⑧ Motor | ⑨ Drive pulley |
| ⑩ Machine cord | ⑪ Control box | ⑫ Operation box cord plug |
| ⑬ Detector cord plug | ⑭ pedal | ⑮ POWER ON/OFF pushbutton |
| ⑯ Operation box | | |

3.2 Machine Head Section (1)
Thread trimming mechanism

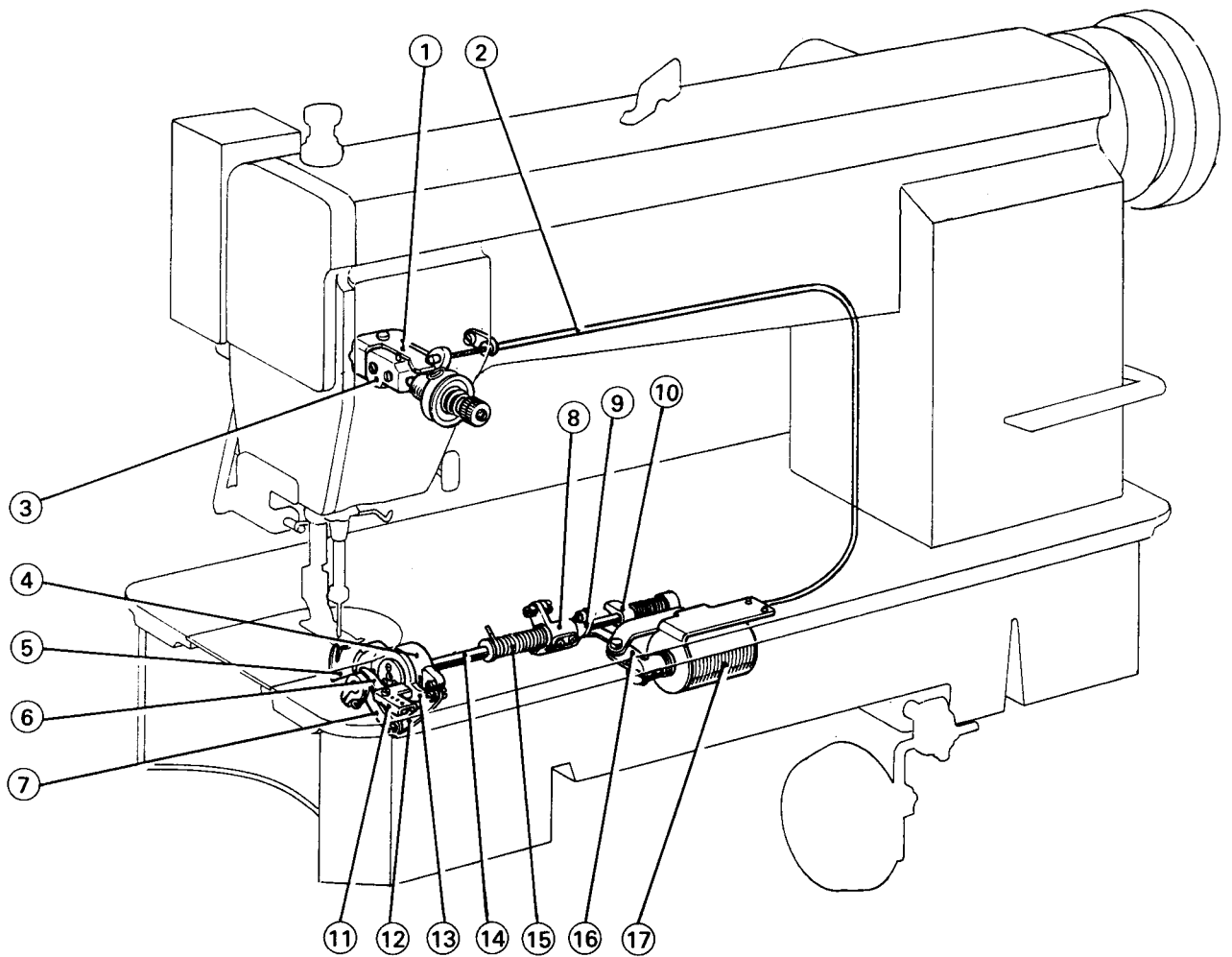

Part Names

- | | | |
|--------------------------------|--------------------------------|----------------------------|
| ① Thread releasing lever | ② Flexible wire | ③ Thread releasing bracket |
| ④ Knife holding bracket saddle | ⑤ Movable knife (left) | ⑥ Fixed blade |
| ⑦ Knife driving crank | ⑧ Cam follower crank (1) | ⑨ Cam follower crank (2) |
| ⑩ Stopper | ⑪ Fixed blade mounting bracket | ⑫ Link |
| ⑬ Knife base (left) | ⑭ Knife driving shaft | ⑮ Coil spring |
| ⑯ Flexible wire driving lever | ⑰ Solenoid for thread trimmer | |

3.2 Machine Head Section (2)

Touch back mechanism

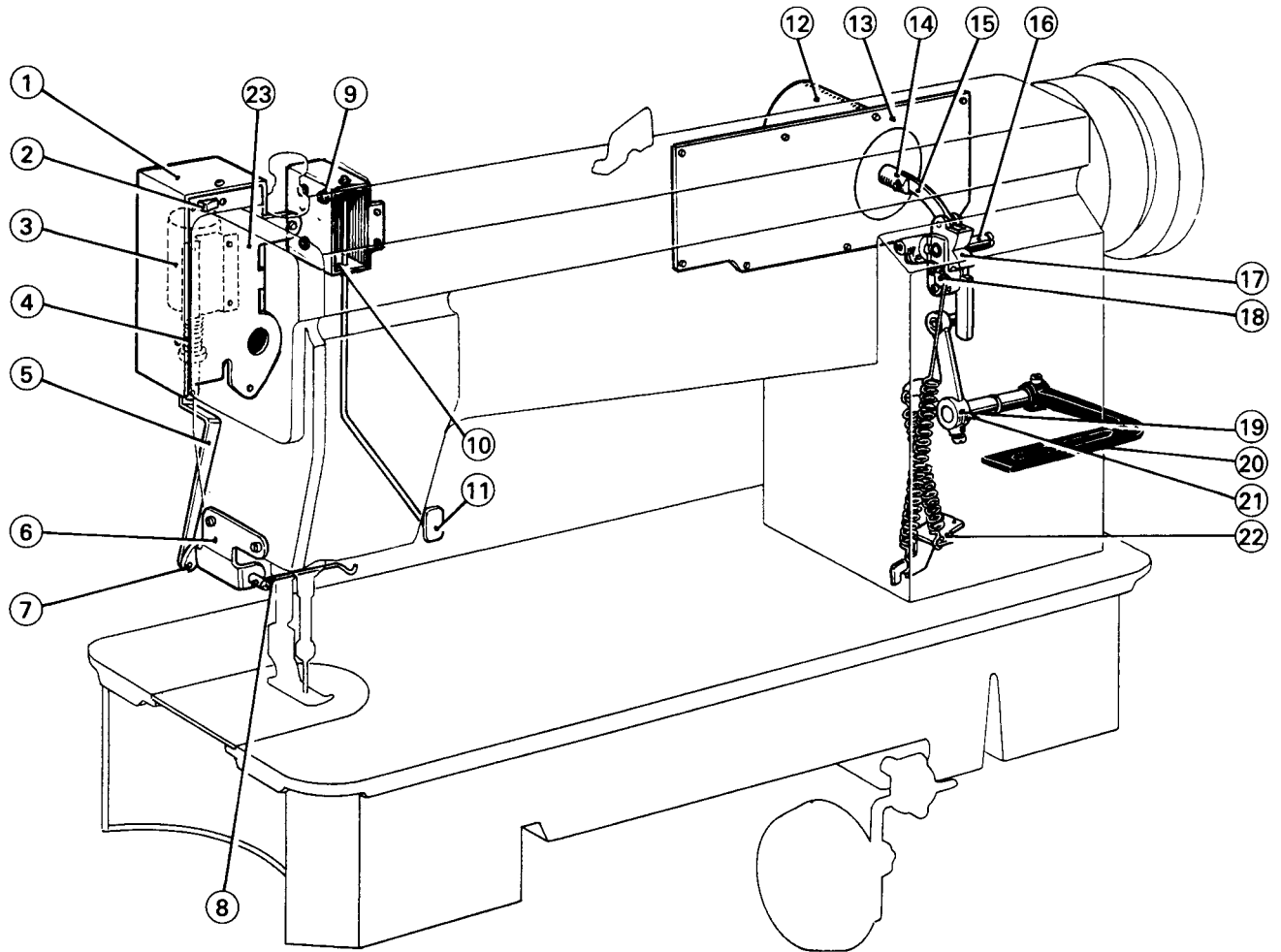

Part Names

- | | | |
|-------------------------|------------------------|----------------------------------|
| ① Cover | ② Switch for wiper | ③ Solenoid for wiper |
| ④ Coil spring | ⑤ Link | ⑥ Wiper bracket |
| ⑦ Wiper shaft | ⑧ Wiper | ⑨ Hinged pin |
| ⑩ Switch for touch back | ⑪ Push button lever | ⑫ Solenoid for touch back |
| ⑬ Arm side cover | ⑭ Plunger | ⑮ Link |
| ⑯ Bushing | ⑰ Feed regulator cam | ⑱ Spring retainer |
| ⑲ Reverse sewing crank | ⑳ Reverse sewing lever | ㉑ Shaft for reverse sewing shaft |
| ㉒ Spring holder | ㉓ Solenoid bracket | |

4. PREPARATIONS BEFORE OPERATION

4.1 Installation of Sewing Machine and Motor

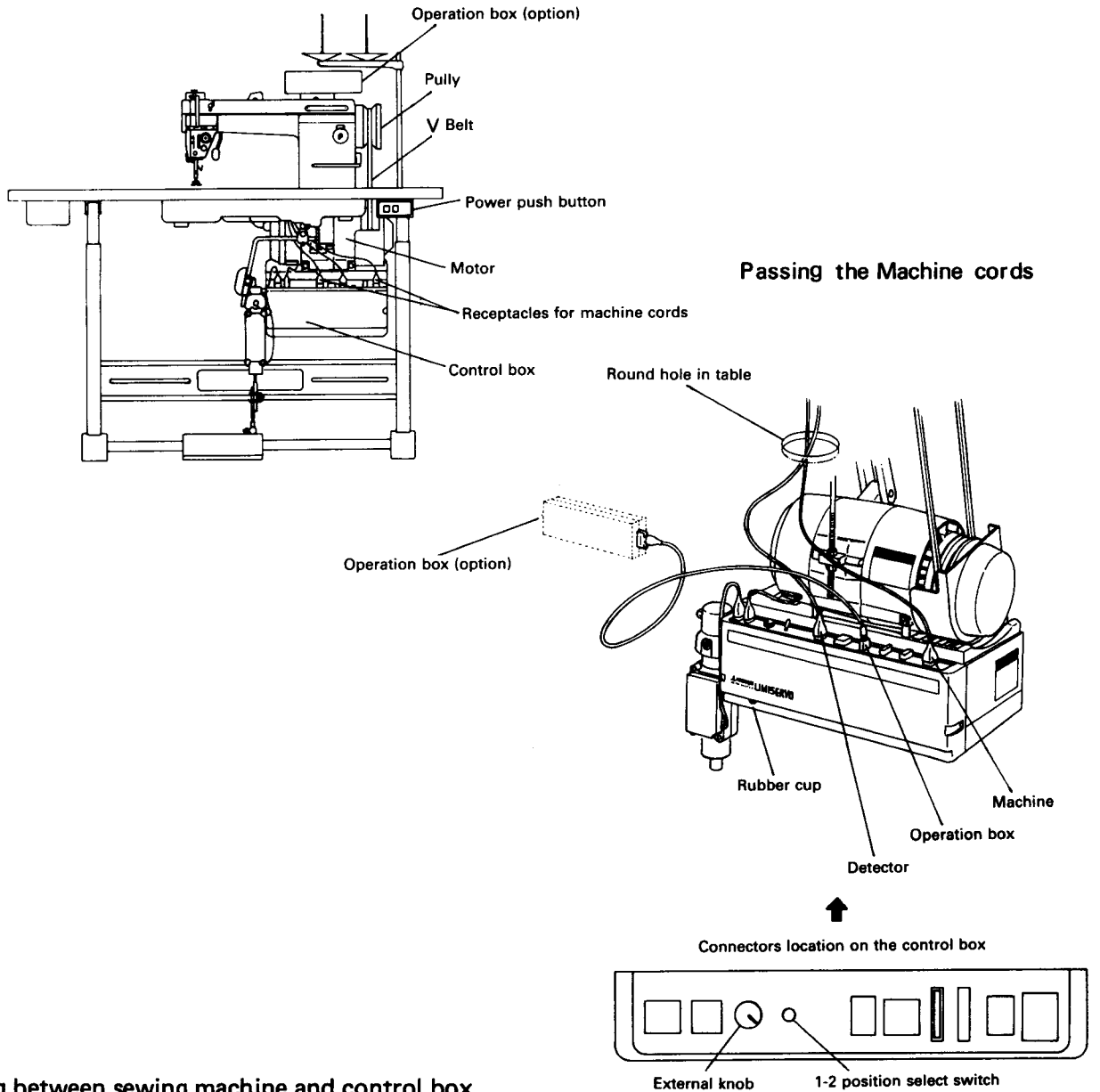

Wiring between sewing machine and control box

Note: Before plugging or unplugging, be sure to turn off the **POWER ON/OFF** pushbutton. Pass two cables from the sewing machine through the round hole in the table and connect the two plugs into the respective plug receptacles.

4.2 Adjustment of Machine Stop Position

4.2.1 Adjust of "UP" position

When the pedal is kicked down by heel, the machine stops at "UP" position. If the marks deviate larger than 3 mm adjust as follows.

- (1) Disconnect the plug (12 pins) of cable from the machine head.
- (2) Run the machine and stop at "UP" position.
- (3) While holding the pulley insert the "adjusting tool" in the hole (A), then remove the tool.

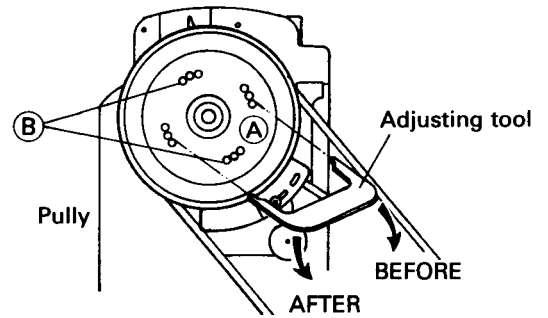

4.2.2 Adjust of "DOWN" position

When the pedal is Newtral the machine stops as "DOWN" position. If the marks deviate larger than 3 mm adjust as follows.

- (1) Disconnect the plug (12 pins) of cable from the machine head.
- (2) Run the machine and stop at "DOWN" position.
- (3) While holding the pulley insert the "adjusting tool" in the hole (B), then remove the tool.

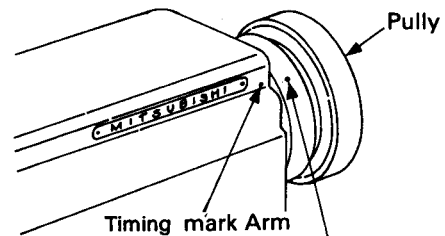
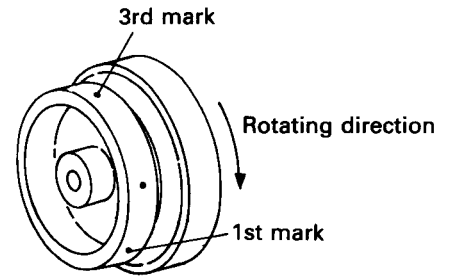

| | |
|----------|-----------------|
| 1st mark | "Up" position |
| 3rd mark | "Down" position |

- ### 4.2.3 Comfirm the stop operation then the plug (12 pins) coming from the machine head into the receptacle.

5 ADJUSTMENTS

5.1 How to Adjust the Timing between Needle and Hook

The standard timing between needle and hook is following the table.

| Item | Sub-class | -M |
|--|-----------|------|
| Needle lift-up quantity from lowest position | (A) | 2.0 |
| Distance between needle and hook point | (C) | 0.05 |
| Distance between needle point and needle plate setting base, in highest position of needle bar | | 18.8 |

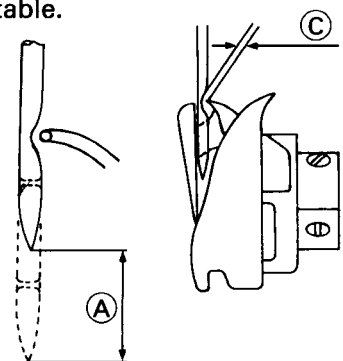

Fig.1

5.2 Thread Trimmer Mechanism

5.2.1 Construction

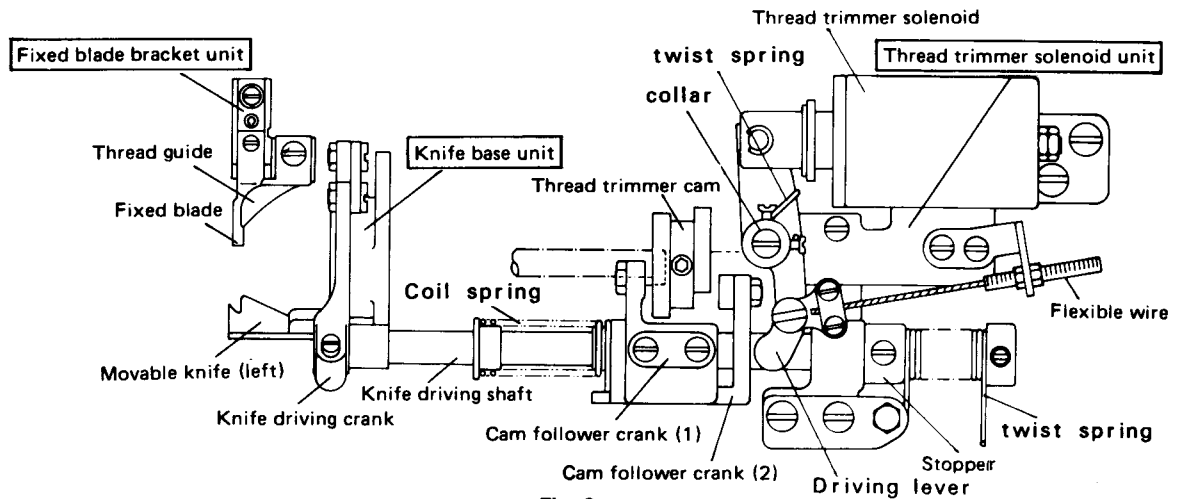

Fig. 2

5.2.2 Cautions on adjustment

A hook shaft cam system is utilized for the thread trimmer drive. Therefore, during the adjustment of sewing machine, if the sewing machine is rotated one turn with the thread trimmer solenoid in the operating state (the roller of cam follower crank (2) is engaged with the thread trimmer cam), the movable knife makes contact with the needle, resulting in damage. Be sure to bring the solenoid into the operating state only during a normal thread trimming cycle (Needle DOWN position to UP position).

5.2.3 Installation of knife base and fixed blade bracket unit

5.2.3.1 Knife base unit

- (1) As shown in Fig. 3, fit the knife base unit to the hook shaft bushing (left) and fix with the screws (A).

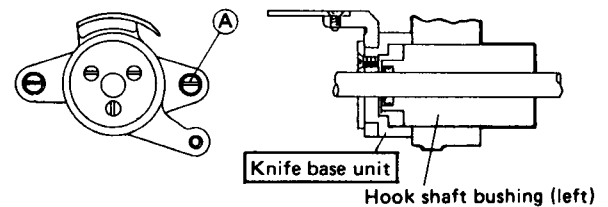

Fig. 3

5.2.3.2 Fixed blade bracket unit

- (1) As shown in Fig. 4, install the fixed blade bracket unit with the hook positioner dismantled, and then fix with the screws (A).

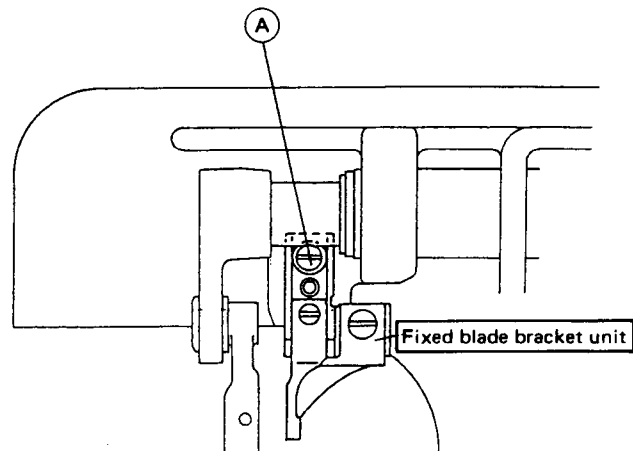

Fig. 4

5.2.3.3 Relation between fixed blade and movable knife (left) edge

- (1) Fig. 5 shows the standard state.
- (2) If the dimension indicated in Fig. 5 is too large, three-thread breakage will occur, leading to needle thread cast-off, etc. after the thread trimming. Reversely, if the dimension is too small, thread trimming error may result. Therefore, caution must be exercised.
- (3) Make the adjustment in (2) in the installation procedure of fixed blade bracket unit or in the installation procedure of fixed blade.

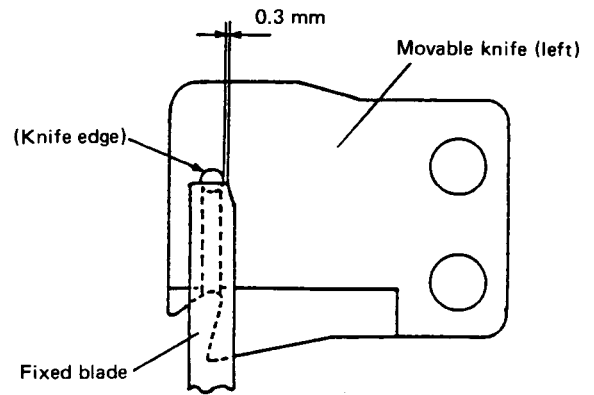

Fig. 5

5.2.4 Connection of knife base and knife driving crank

- (1) Make connection as shown in Fig. 6. At this time, use care for the position of link depends on the sewing machine model.

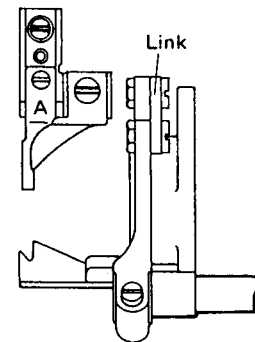

Fig. 6

5.2.5 Knife driving shaft and related parts

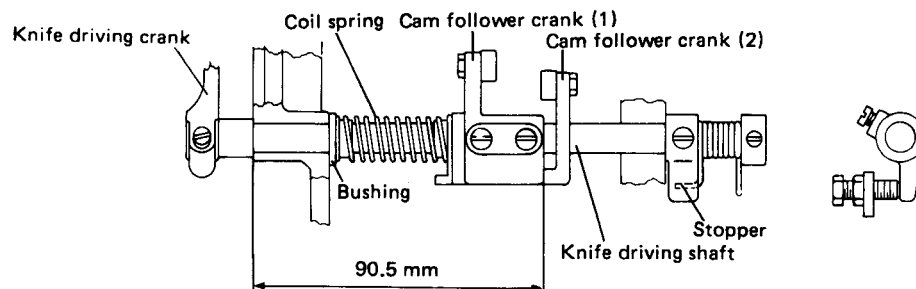

Fig. 7

- (1) Fig. 7 shows the standard setting position.
- (2) During assembling, be sure to pass the knife driving shaft through the knife driving crank first.
- (3) Fix the cam follower crank (1) to the recess of knife driving shaft at the position shown in Fig. 7.
- (4) Fix the stopper to the recess so that the knife driving shaft can rotate smoothly without play in the axial direction.

5.2.6 Installation of thread trimmer solenoid unit

(1) Operation stroke of thread trimmer solenoid

- ① Standard operation stroke is 6.0 mm.
- ② Adjust the operation stroke by use of the nut (A).

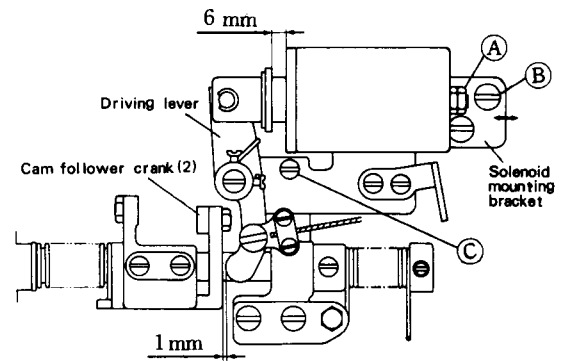

Fig. 8

(2) Installation of unit

- ① Install the unit with the screws (B) and (C) shown in Fig. 8.
- ② Install the unit so that approximately 1 mm is provided between the driving lever and cam follower crank (2) with the stopper nut (A) in contact with the solenoid.
- ③ When the solenoid is energized under this condition, clearance of 0.5 mm is provided between the cam follower cranks (1) and (2) as shown in Fig. 9. This is the standard installation status. Make adjustment by moving the solenoid mounting bracket in the arrow direction in Fig. 8.

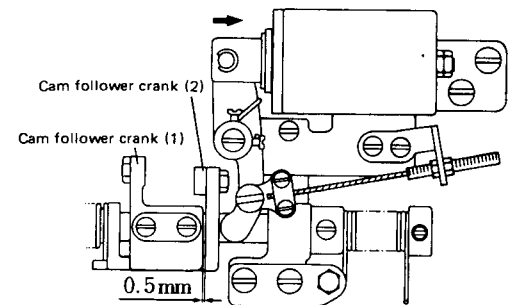

Fig. 9

5.2.7 Installation of thread trimmer cam

- (1) Align the second timing mark (A) on the pulley with the matching mark on the arm.
- (2) Set the thread trimmer solenoid to the operation state and turn the thread trimmer cam forward. At the point where the cam makes contact with the roller, fix the cam.
- (3) When the operation of thread trimmer solenoid has been reset and the cam follower crank (2) has returned, the standard clearance between the cam and roller end is 0.5 to 1.0 mm.

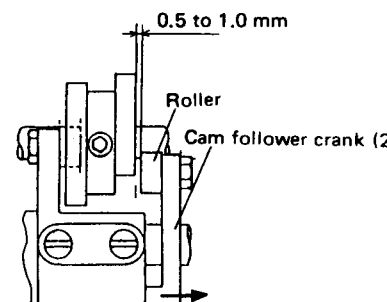
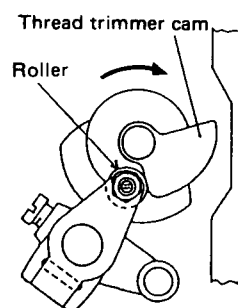
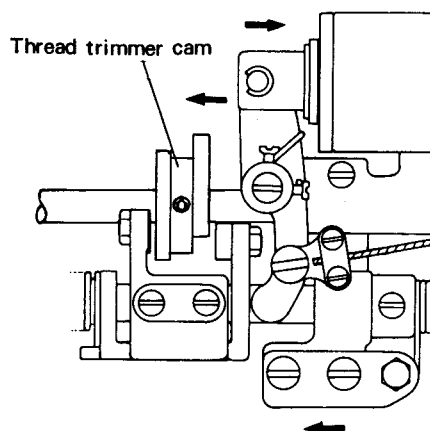
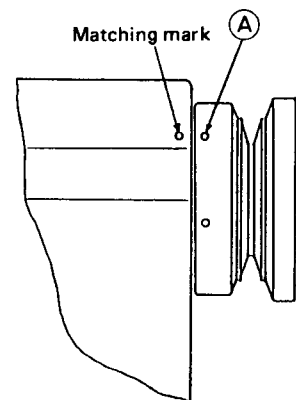

Fig. 10

Note: The standard position of cam follower crank (2) prior to the operation is shown in Fig. 11. When this position has been changed, for example, by removing the stopper plate, make adjustment with the adjust screw (Fig. 7) and then make adjustment in (1) to (3).

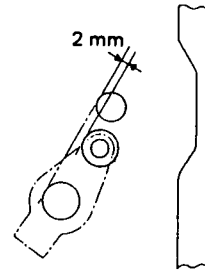

Fig. 11

5.2.8 Adjustment of knife engagement

(1) Positions of movable knife (left) and fixed blade

- ① Fig. 12 shows the standard state, with the feed dial set to zero.

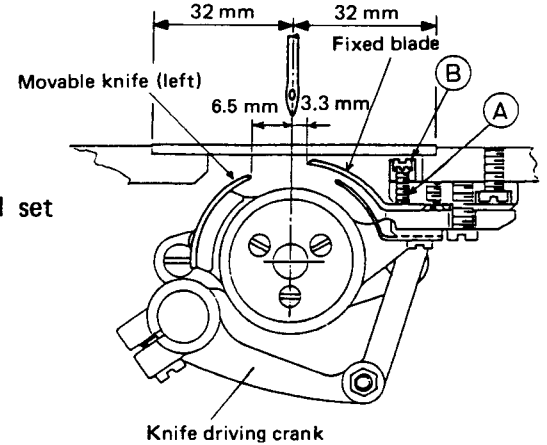

Fig. 12

(2) Adjustment of knife engagement amount

- ① Set the solenoid to the operation state and rotate the sewing machine. Then, the movable knife (left) is rotated by the thread trimmer cam. When the movable knife (left) has moved to the maximum, the standard engagement amount is 1.5 to 2.0 mm. See Fig. 13.
- ② Make adjustment by the installation of knife driving crank.

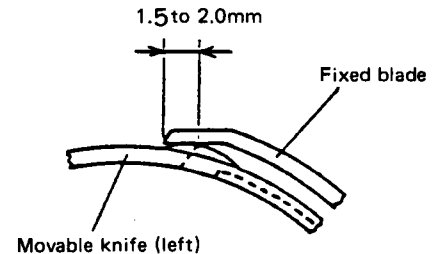

Fig. 13

(3) Adjustment of knife engagement pressure

- ① The standard knife engaging pressure is obtained when the movable knife (left) and fixed blade start making contact with each other at the position shown in Fig. 14.
- ② When cutting action is poor especially because of thick thread, a slight increase of the engagement pressure produces an effect.
- ③ To adjust the engagement pressure, loosen the lock nut (B) in Fig. 11 and adjust with the adjust screw (A).

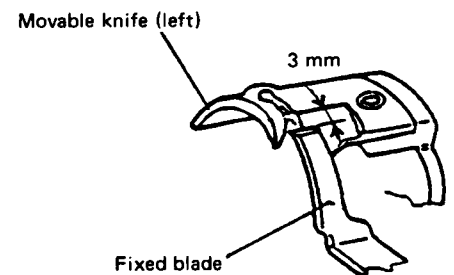

Fig. 14

5.2.9 Adjustment of needle thread tension releasing amount

- (1) Make adjustment so that when the thread trimmer solenoid is operated, the tension discs of thread tension regulator open approximately 1 mm.
- (2) To make adjustment, loosen the nuts (A) and move the flexible wire.

CAUTION

If the opening of tension discs is too small, the needle thread will be trimmed at short length, leading to needle thread cast-off. Reversely, if the opening of tension discs is too large, the tension discs are left opened continuously, leading to loose stitches.

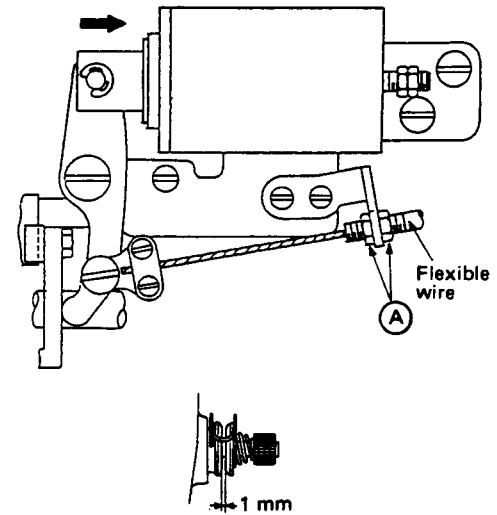

Fig. 15

5.3 Adjustment of Needle Thread Remaining Length

- (1) Adjust the remaining length of needle thread by use of the pretension adjust nut (A).
Clockwise turn reduces the remaining length. Counterclockwise turn increases the length.

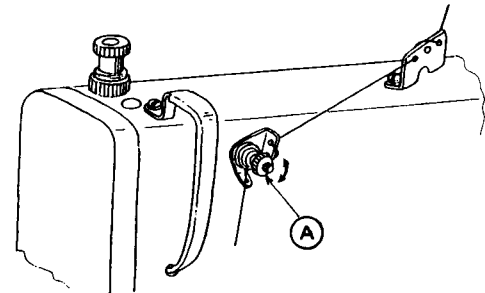

Fig. 16

5.4 Cautions on Installation of Touch-Back Solenoid

Adjust the position of solenoid in the longitudinal direction so that the plunger of solenoid and the link (for connection) are not twisted, and make sure that the reverse sewing lever moves smoothly in the vertical direction. After that, tighten the mounting screws. See Fig. 17.

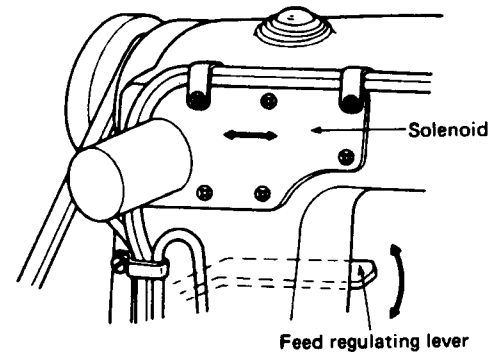

Fig. 17

5.5 Touch-Back Pushbutton

The screw (A) is loosened, the position of pushbutton can be adjusted vertically.

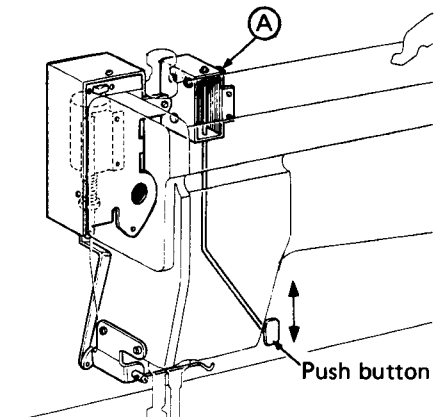
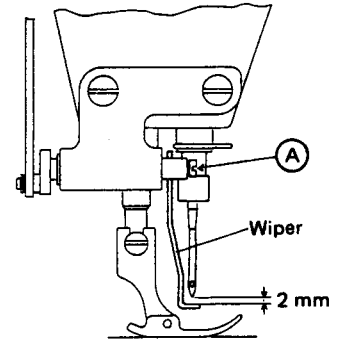

Fig. 18

5.6 Wiper

5.6.1 Height of wiper

- (1) The standard height of wiper is 2 mm below the tip of needle which is stopped at the UP position.
- (2) Make adjustment after loosening the screw (A).



5.6.2 Wiper operation position

- (1) The standard operation position of wiper is 0 to 2 mm from the center of needle when the plunger of wiper solenoid is fully pushed (when the solenoid is energized).
- (2) To make adjustment, loosen the screws (B) and (C) and then adjust the mounting position of solenoid unit.

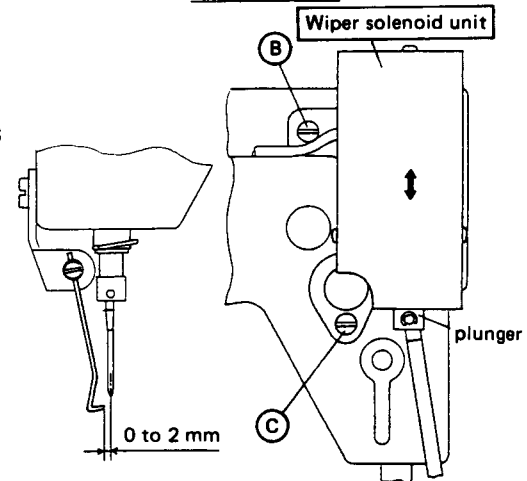

Fig. 19

5.7 Adjustment of Forward and Reverse Stitch Lengths

Loosen the screw (A) and make adjustment by turning the eccentric shaft (B). Clockwise turn increase the forward stitch length and decreases the reverse stitch length. Counterclockwise turn decreases the forward stitch length and increases the reverse stitch length.

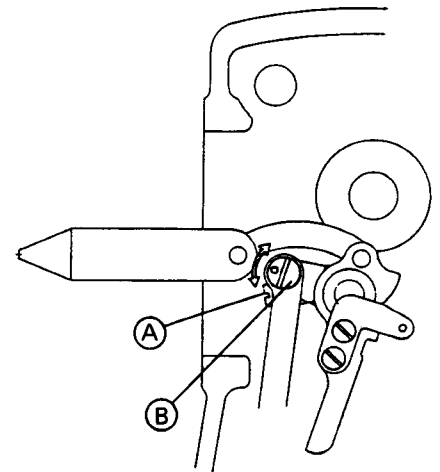

Fig. 20

5.8 Adjustment of Feed Dog Inclination

To adjust the inclination of feed dog, loosen the screw (A) and turn the eccentric pin (B). Clockwise turn sets to downward tilt. Counterclockwise turn sets to upward tilt.

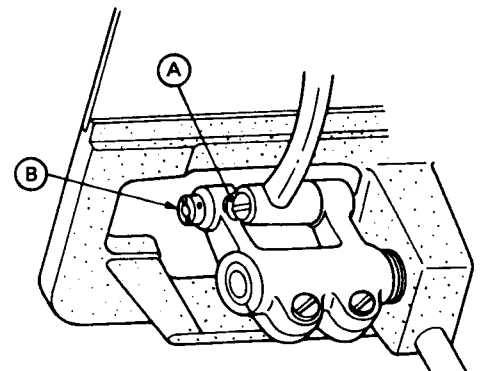

Fig. 21

5.9 Timing of Feed

- (1) The position for the standard feed timing is where the needle tip is approximately 0 to 3 mm from the upper surface of needle plate when the feed dog is risen by turning the balance wheel and the teeth of feed dog become flush with the upper surface of needle plate. See Fig. 22.

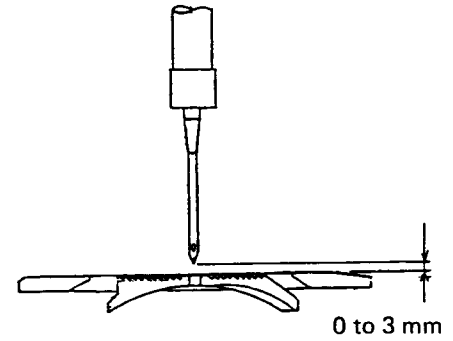

Fig. 22

- (2) Make adjustment by the mounting positions of feed cam.

To install, timing mark on a feed cam is according with oiling hole on a upper shaft, by set screw as shown in Fig. 23.

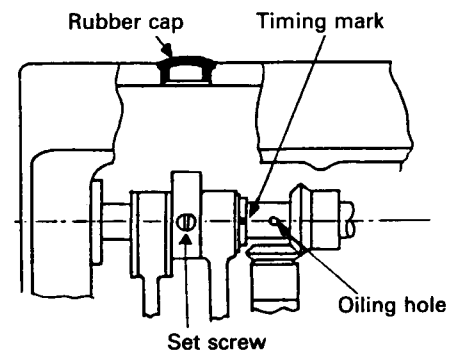

Fig. 23

5.10 Relation between Needle and Feed Dog

(Make correction so that the needle drops to the needle hole center of feed dog.)

(1) Set the stitch length dial to 0.

(2) Remove the face plate.

(3) Tilt the machine head toward the opposite side.

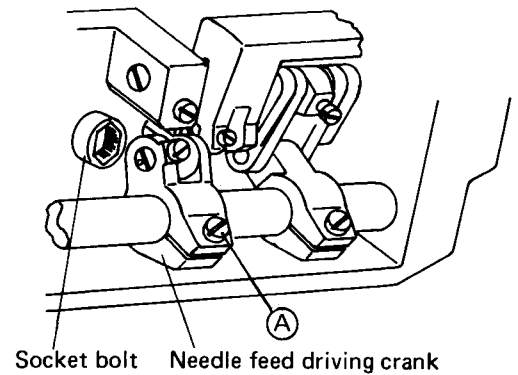

(4) Loosen the set screw **A** of needle feed driving crank at the rear surface of bed and make adjustment as shown in the feed regulator crank.

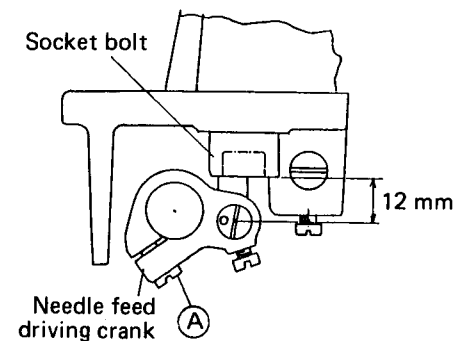

Fig. 24

(5) At this time, make sure that there is clearance as shown in the figure between the needle feed driving crank and feed regulator crank.

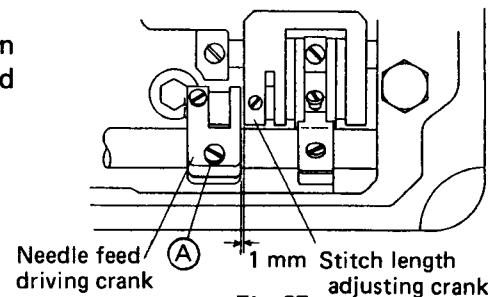

Fig. 25

(6) Loosen the set screw **B** of needle feed rod crank (left) and make adjustment so that the needle is located at the center of needle plate.

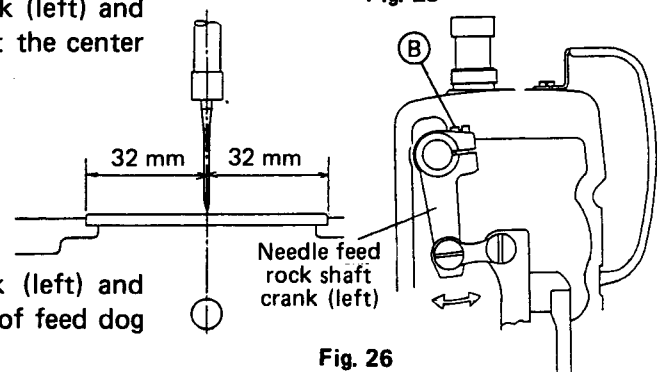

Fig. 26

(7) Loosen the screw **C** of feed rock shaft crank (left) and make adjustment so that the needle hole center of feed dog is aligned with the needle.

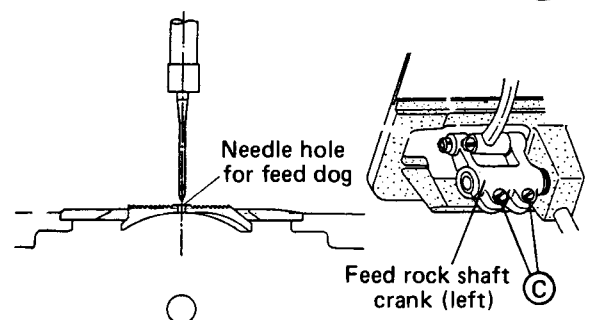

Fig. 27

5.11 Adjustment of Needle Feed Amount

When uneven material feeding occurs depending on fabrics, adjust the eccentric set pin of needle feed driving crank to increase the needle feed amount.

(1) Set the feed regulating dial to 0.

(2) Loosen the screw (A) and then make adjustment by turning the eccentric set pin (B).

When the mark (C) is located on the feed rock shaft side, the needle feed amount is the same as the feed amount of feed dog.

When the mark (C) is located on the opposite side to the feed rock shaft, the needle feed amount is the maximum (110% of the feed amount of feed dog).

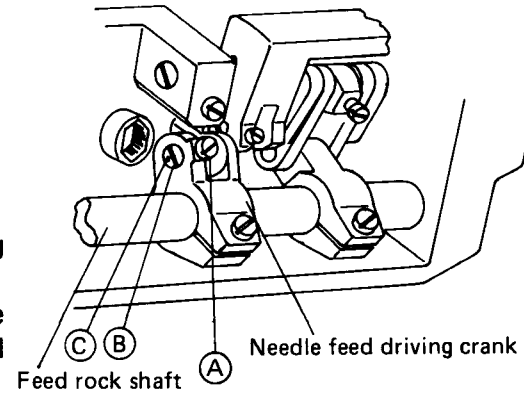

Fig. 28

(3) When the above adjustment has been made, the needle hole center of feed dog is misaligned with the needle. Therefore, remove the face plate, loosen the screw (D) of needle feed rod crank (left), and make adjustment so that the needle drops to the needle hole center of feed dog.

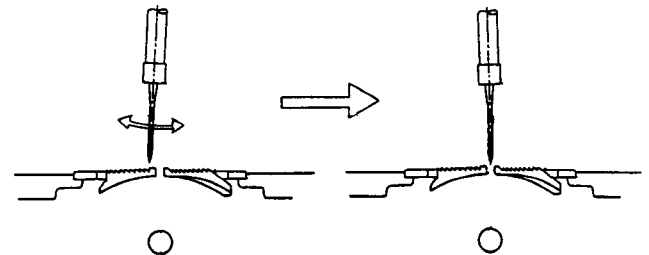
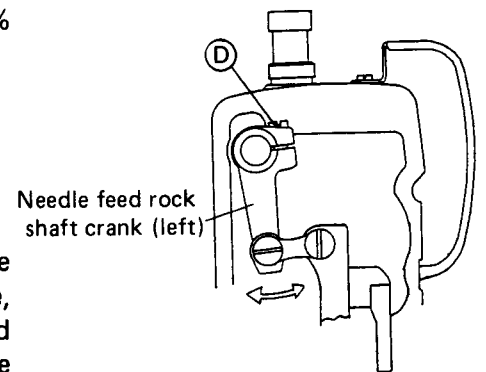

Fig. 29

(4) While the feed motion is performed with the feed dial set to the maximum value, check if the needle does not make contact with the needle hole of feed dog by turning the balance wheel.

5.12 Hook, Bobbin Case, and Bobbin

- (1) Use the undertrimmer hook which has the bobbin thread guide slit (A) as shown in Fig. 30.

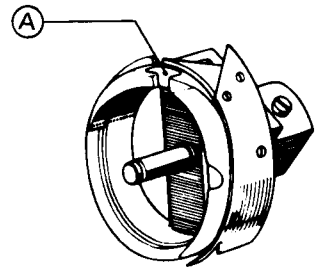

Fig. 30

- (2) Use the bobbin case which has idle running prevention spring (A) at the bottom as shown in Fig. 31.

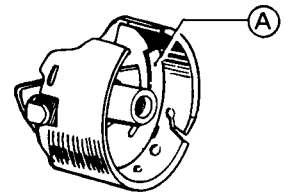

Fig. 31

- (3) For the bobbin, use the attached bobbin. In order to prevent the deformation of bobbin, wind the thread as lightly as possible.

6. TROUBLESHOOTING

| Trouble | Cause | Corrective Action | Reference Section |
|--|--|---|---|
| Thread cannot be trimmed. | <p>Knife engagement is improper.</p> <p>Knife engaging pressure is too low.</p> <p>Damage and/or wear of cutting edge of movable knife (left), fixed blade</p> <p>Machine stops too early.</p> <p>Machine stop position varies largely.</p> <p>Position of fixed blade is improper.</p> <p>Since the movable knife (left) is operated too early, loop spreading cannot be performed by the knife.</p> | <p>Adjust the engagement amount.</p> <p>Adjust the engaging pressure.</p> <p>Change the knife and/or blade.</p> <p>Adjust the stop position.</p> <p>Check needle thread tension at the time of thread trimming.</p> <p>Adjust the position of fixed blade.</p> <p>Adjust the installation of thread trimmer cam.</p> | <p>5.2.8</p> <p>5.2.8</p> <p>5.2.8</p> <p>4.2</p> <p>5.2.9</p> <p>5.2.3</p> <p>5.2.7</p> |
| Needle thread comes out of the needle at the start of stitching. | <p>At the time of thread trimming, thread tension regulator discs do not open.</p> <p>Thread trimmer timing is too early.</p> <p>Thread is trimmed by the fixed blade before the cutting edge of movable knife (left) engage with the fixed blade.</p> <p>Needle is too thick with respect to the thread. Pretension is too strong.</p> | <p>Adjust the needle thread tension releasing.</p> <p>Adjust the installation of thread trimmer cam.</p> <p>Adjust the position of fixed blade.</p> <p>Adjust the pretension.</p> | <p>5.2.9</p> <p>5.2.7</p> <p>5.2.3</p> <p>5.3</p> |
| Skip stitch at the start of stitching | <p>Bobbin thread becomes short due to the idle running of bobbin at the thread trimming.</p> <p>Tension of bobbin thread is too strong.</p> <p>The remaining length of needle thread on the needle side is too short after thread trimming.</p> | <p>Use a bobbin case with idle running prevention spring.</p> <p>Adjust the tension of bobbin thread.</p> <p>1. Adjust the pretension. 2. Check the installation of thread trimmer cam. 3. Check the thread contact area.</p> | <p>5.10</p> <p>5.3</p> <p>5.2.7</p> |
| Needle thread is too long after thread trimming. | <p>Pretension is too weak.</p> <p>Thread trimmer timing is too late.</p> <p>Thread movement between the hook and the hook positioner is not smooth.</p> | <p>Adjust the pretension.</p> <p>Adjust the installation of thread trimmer cam.</p> | <p>5.3</p> <p>5.2.7</p> |